

描述 / Descriptions

XR4054B是一款完整的单节锂离子电池采用恒定电流/恒定电压线性充电器。其SOT封装与较少的外部元件数目使得XR4054B成为便携式应用的理想选择。XR4054B可以适合USB电源和适配器电源工作。

The XR4054B is a complete constant-current/constant voltage linear charger for single cell lithium-ion batteries. Its Thin SOT package and low external component count make the XR4054B ideally suited for portable applications. Furthermore, the XR4054B is specifically designed to work within USB power specifications.

由于采用了内部PMOSFET架构，加上防倒充电路，所以不需要外部检测电阻器和隔离二极管。热反馈可对充电电流进行调节，以便在大功率操作或高环境温度条件下对芯片温度加以限制。充电电压固定于4.2V，而充电电流可通过一个电阻器进行外部设置当充电电流在达到最终浮充电压之后降至设定值1/10时，XR4054B将自动终止充电循环。

No external sense resistor is needed, and no blocking diode is required due to the internal MOSFET architecture. Thermal feedback regulates the charge current to limit the die temperature during high power operation or high ambient temperature. The charge voltage is fixed at 4.2V, and the charge current can be programmed externally with a single resistor. The XR4054B automatically terminates the charge cycle when the charge current drops to 1/10th the programmed value after the final float voltage is reached.

当输入电压（交流适配器或USB电源）被拿掉时，XR4054B自动进入一个低电流状态，将电池漏电流降至2 μ A以下。也可将XR4054B置于停机模式，以而将供电电流降至25 μ A。XR4054B的其他特点包括充电电流监控器、欠压闭锁、自动再充电和一个用于指示充电结束和输入电压接入的状态引脚。

When the input supply (wall adapter or USB supply) is removed, the XR4054B automatically enters a low current state, dropping the battery drain current to less than 2 μ A. The XR4054B can be put into shutdown mode, reducing the supply current to 25 μ A. Other features include charge current monitor, under voltage lockout, automatic recharge and a status pin to indicate charge termination and the presence of an input voltage.

特征 / Features

- › 高达800mA的可编程充电电流
Programmable Charge Current Up to 800mA
- › 无需MOSFET、检测电阻器或隔离二极管
No MOSFET, Sense Resistor or Blocking Diode Required
- › 用于单节锂离子电池、采用SOT23-5封装的完整线性充电器
Complete Linear Charger in 5-Lead SOT-23 Package for Single Cell Lithium-Ion Batteries
- › 恒定电流/恒定电压操作，并具有热调节功能
Constant-Current/Constant-Voltage Operation with Thermal Regulation to Maximize Charge Rate Without Risk of Overheating
- › 直接从USB端口给单节锂离子电池充电
Charges Single Cell Li-Ion Batteries Directly from USB Port
- › 4.2V预设充电电压
Preset 4.2V Charge Voltage with $\pm 1\%$ Accuracy
- › 用于电池电量检测的充电电流监控器输出
Charge Current Monitor Output for Gas Gauging
- › 自动再充电
Automatic Recharge

特征 / Features

- › 充电状态输出引脚
Charge Status Output Pin
- › C/10充电终止
C/10 Charge Termination 待机模式下的供电电流为25 μ A 25 μ A
Supply Current in Shutdown 2.9V
- › 涓流充电器件版本
2.9V Trickle Charge Threshold
- › 软启动限制了浪涌电流
Soft-Start Limits Inrush Current
- › 单灯使用时，充满后灯全灭。
When using a single lamp, the light is completely extinguished after fully charging..
- › 无卤产品。
Halogen-free Product.

用途 / Applications

- › 蜂窝电话、PDA、MP3播放器；
Cellular Telephones, PDAs, MP3 Players
- › 充电座
Charging Docks and Cradles
- › 蓝牙应用
Bluetooth Applications.

内部等效电路 / 应用电路 Equivalent Circuit or Application Circuit

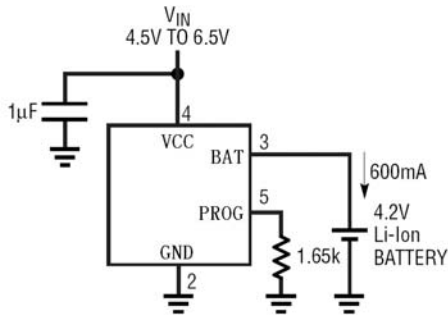

引脚排列 / Pinning

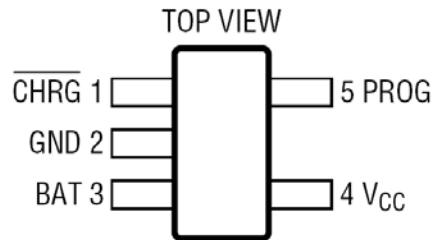

CHRG (引脚1):漏极开路充电状态输出。在电池的充电过程中，由一个内部N沟道MOSFET将CHRG引脚拉至低电平。当充电循环结束时，一个约20uA的弱下拉电流源被连接至CHRG引脚，指示一个AC存在状态。当XR4054B检测到一个欠压闭锁条件时，CHRG引脚被强制为高阻抗状态。

CHRG (Pin 1): Open-Drain Charge Status Output. When the battery is charging, the $\overline{\text{CHRG}}$ pin is pulled low by an internal N-channel MOSFET. When the charge cycle is completed, a weak pull-down of approximately 20 μ A is connected to the $\overline{\text{CHRG}}$ pin, indicating an “AC present” condition. When the XR4054B detects an under voltage lockout condition, $\overline{\text{CHRG}}$ is forced high impedance.

GND (引脚2): 地。

GND (Pin 2) : Ground.

BAT (引脚3):充电电流输出。该引脚向电池提供充电电流并将最终浮充电压调节至4.2V该引脚的一个精准内部电阻分压器设定浮充电压，在停机模式中，该内部电阻分压器断开。

BAT (Pin 3): Charge Current Output. Provides charge current to the battery and regulates the final float voltage to 4.2V. An internal precision resistor divider from this pin sets the float voltage which is disconnected in shut down mode.

V_{CC} (引脚4) : 正的输入电源电压。该引脚向充电器供电。V_{CC}的变化范围在4.25V-6.5V之间，并应通过至少一个1uF电容器进行旁路。当V_{CC}降至BAT引脚电压的30mV以内，XR4054B进入停机模式，从而I_{BAT}降至2uA以下。

V_{CC} (Pin 4): Positive Input Supply Voltage. Provides power to the charger. V_{CC} can range from 4.25V to 6.5V and should be bypassed with at least a 1 μ F capacitor. When V_{CC} drops to within 30mV of the BAT pin voltage, the XR4054B enters shutdown mode, dropping I_{BAT} to less than 2 μ A.

引脚排列 / Pinning

PROG (引脚5): 充电电流设定, 充电电流监控和停机引脚。在该引脚与地之间连接一个精度为1%的电阻器 R_{PROG} 可以设定充电电流。当在恒定电流模式下进行充电时, 该引脚的电压被维持在1V在所有的模式中都可以利用该引脚上的电压来测算充电电流, 公式为 $I_{BAT} = (V_{PROG}/R_{PROG}) * 1000$ 。

PROG引脚还可以用来关断充电器。将设定电阻器与地短接, 内部一个3.0uA 电流将PROG引脚拉至高电平。当该引脚的电压达到1.21V的停机门限电压时, 充电器进入停机模式, 充电停止且输入电源电流降至25uA。该引脚还夹约2.4V, 电流1.5mA, 重新将 R_{PROG} 与地相连将使充电器恢复正常操作状态。

PROG (Pin 5): Charge Current Program, Charge Current Monitor and Shutdown Pin. The charge current is programmed by connecting a 1% resistor, R_{PROG} , to ground. When charging in constant-current mode, this pin serves to 1V. In all modes, the voltage on this pin can be used to measure the charge current using the following formula: $I_{BAT} = (V_{PROG}/R_{PROG}) \times 1000$.

The PROG pin can also be used to shut down the charger. Disconnecting the program resistor from ground allows a 3uA current to pull the PROG pin high. When it reaches the 1.21V shutdown threshold voltage, the charger enters shutdown mode, charging stops and the input supply current drops to 25uA. This pin is also clamped to approximately 2.4V. Driving this pin to voltages beyond the clamp voltage will draw currents as high as 1.5mA. Reconnecting R_{PROG} to ground will return the charger to normal operation.

印章代码 / Marking

见印章说明。See Marking Instructions

极限参数 / Absolute Maximum Ratings(Ta=25°C)(Note 1)

参数 Parameter	数值 Rating	单位 Unit
Input Supply Voltage (V _{CC})	-0.3 to 10	V
PROG	-0.3 to V _{CC} + 0.3	V
BAT	-0.3 to 7	V
CHRG	-0.3 to 10	V
BAT Short-Circuit Duration	Continuous	
BAT Pin Current	800	mA
PROG Pin Current	800	μA
Maximum Junction Temperature	125	°C
Operating Ambient Temperature Range(Note 2)	-40~85	°C
Storage Temperature Range	-65~125	°C
Lead Temperature (Soldering, 10sec)	300	°C

电性能参数 / Electrical Characteristics(Ta=25°C, V_{CC}=5V)

参数 Parameter	符号 Symbol	测试条件 Test Conditions	最小值 Min	典型值 Typ	最大值 Max	单位 Unit
Input Supply Voltage	V _{CC}		4.25		6.5	V
Input Supply Current	I _{CC}	Charge Mode (Note 3), R _{PROG} =10k		300	2000	μA
		Standby Mode (Charge Terminated)		200	500	μA
		Shutdown Mode (R _{PROG} Not Connected V _{CC} <V _{BAT} , or V _{CC} <V _{UV})		25	50	μA
Regulated Output (Float) Voltage	V _{FLOAT}	0°C ≤ T _A ≤ 85°C I _{BAT} = 40mA	4.158	4.20	4.242	V
BAT Pin Current	I _{BAT}	R _{PROG} =10k Current Mode	93	100	107	mA
		R _{PROG} =2k Current Mode	465	500	535	mA
		Standby Mode V _{BAT} =4.2V	0	-2.5	-6.0	μA
		Shutdown Mode (R _{PROG} Not Connected)		±1.0	±2.0	μA
		Sleep Mode V _{CC} = 0V		±1.0	±2.0	μA
Trickle Charge Current	I _{TRIKL}	V _{BAT} < V _{TRIKL} R _{PROG} =2k	20	45	70	mA
Trickle Charge Threshold Voltage	V _{TRIKL}	R _{PROG} =10k, V _{BAT} Rising (Note5)	2.8	2.9	3.0	V
Trickle Charge Hysteresis Voltage	V _{TRHYS}	R _{PROG} = 10k	60	80	110	mV

电性能参数 / Electrical Characteristics(Ta=25°C)

参数 Parameter	符号 Symbol	测试条件 Test Conditions	最小值 Min	典型值 Typ	最大值 Max	单位 Unit
V _{CC} Undervoltage Lockout Threshold	V _{UV}	From V _{CC} Low to High	3.7	3.8	3.92	V
V _{CC} Undervoltage Lockout Hysteresis	V _{UVHYS}		150	200	300	mV
Manual Shutdown Threshold Voltage	V _{MSD}	PROG Pin Rising	1.15	1.21	1.30	V
		PROG Pin Falling	0.9	1.0	1.1	V
V _{CC} – V _{BAT} Lockout Threshold Voltage	V _{ASD}	V _{CC} from Low to High	70	100	140	mV
		V _{CC} from High to Low	5.0	30	50	mV
C/10 Termination Current Threshold	I _{TERM}	R _{PROG} =10k (Note4)	0.085	0.10	0.115	mA/mA
		R _{PROG} =2k	0.085	0.10	0.115	mA/mA
PROG Pin Voltage	V _{PROG}	R _{PROG} =10k Current Mode	0.93	1.0	1.07	V
CHRG Pin Weak Pull-Down Current	I _{CHRG}	V _{CHRG} =5V	8.0	20	35	μA
CHRG Pin Output Low Voltage	V _{CHRG}	I _{CHRG} = 5mA		0.35	0.60	V
Recharge Battery Threshold Voltage	V _{RECHRG}	V _{FLOAT} -V _{RECHRG}	100	150	200	mV
Junction Temperature in Constant Temperature Mode	T _{LIM}			120		°C
Power FET “ON” Resistance (Between V _{CC} and BAT)	R _{ON}			600		mΩ
Soft-Start Time	t _{SS}	I _{BAT} =0 to I _{BAT} =1000V/R _{PROG}		100		μs
Recharge Comparator Filter Time	t _{RECHARGE}	V _{BAT} High to Low	0.75	2.0	4.5	ms
Termination Comparator Filter Time	t _{TERM}	I _{BAT} Falling Below I _{CHG} /10	400	1000	2500	μs
PROG Pin Pull-Up Current	I _{PROG}			3.0		μA

Notes:

Note 1: Absolute Maximum Ratings are those values beyond which the life of the device may be impaired.

Note 2: The XR4054B-4.2 is guaranteed to meet performance specifications from 0°C to 70°C. Specifications over the –40°C to 85°C operating temperature range are assured by design, characterization and correlation with statistical process controls.

Note 3: Supply current includes PROG pin current (approximately 100μA) but does not include any current delivered to the battery through the BAT pin (approximately 100mA).

Note 4: I_{TERM} is expressed as a fraction of measured full charge current with indicated PROG resistor.

原理框图 / Functional Block Diagram

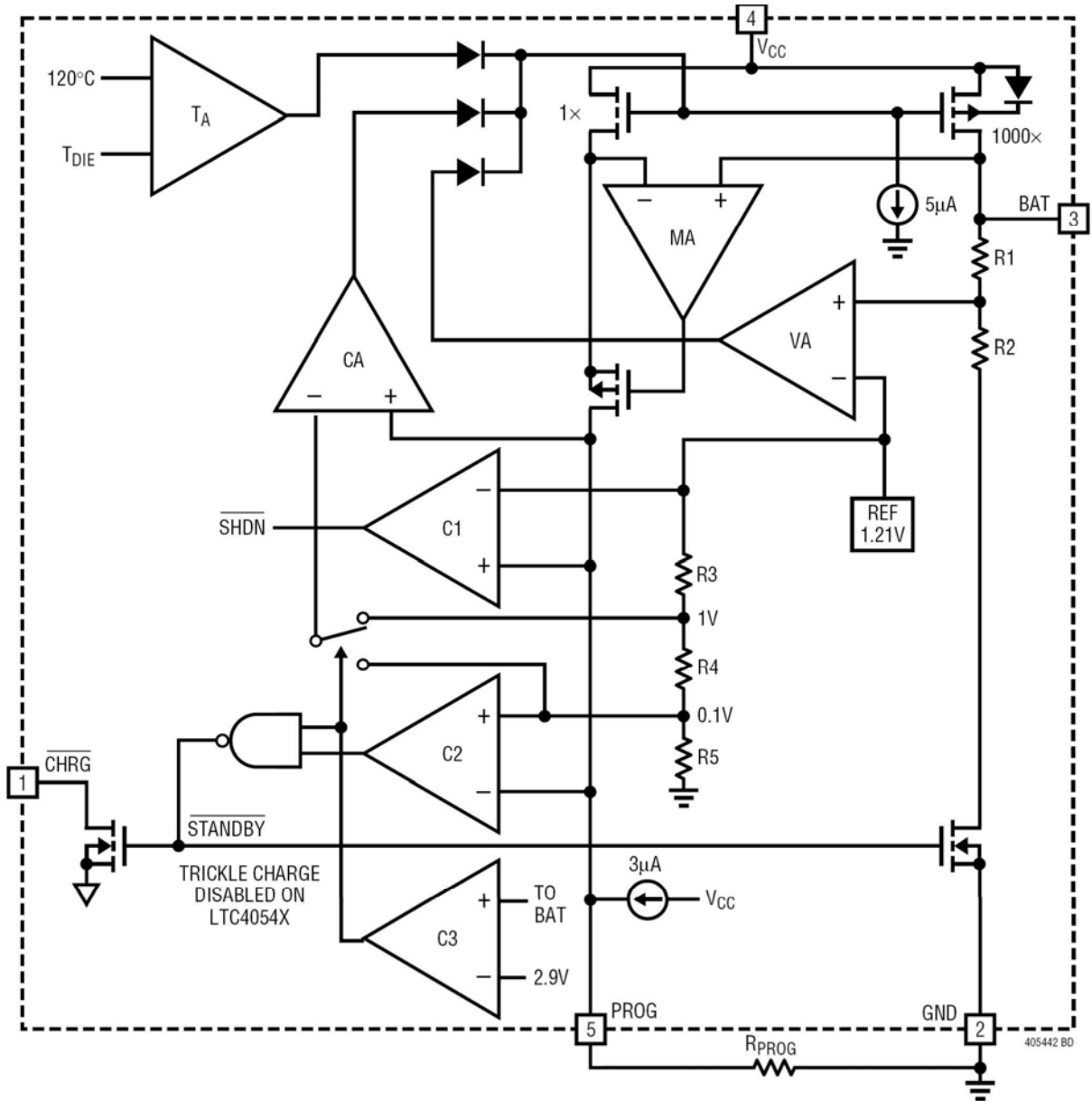

电参数曲线图 / Electrical Characteristic Curve

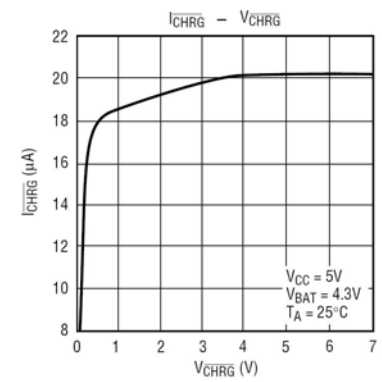
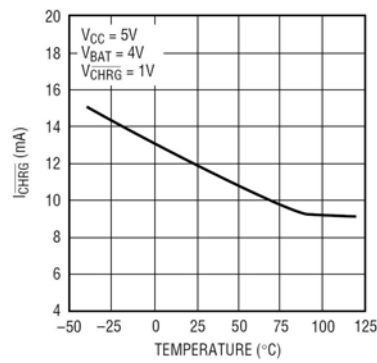
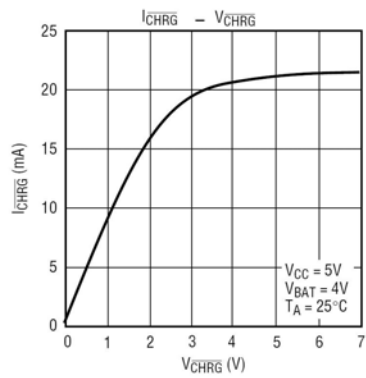
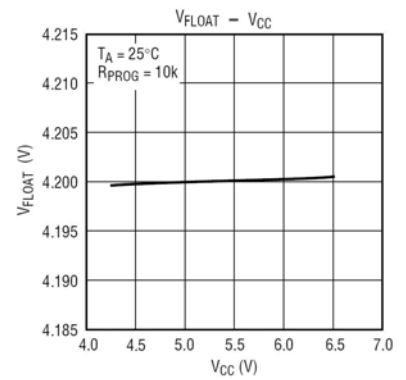
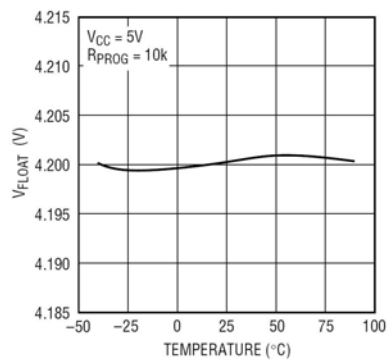
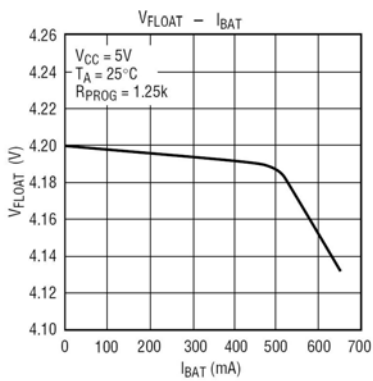
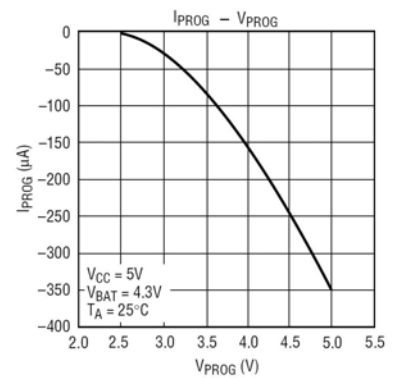
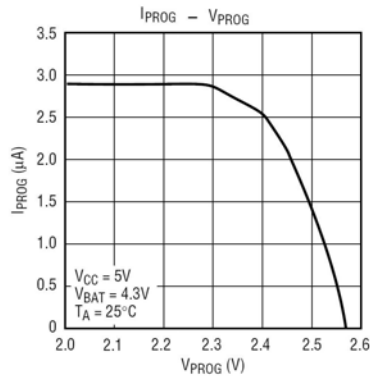
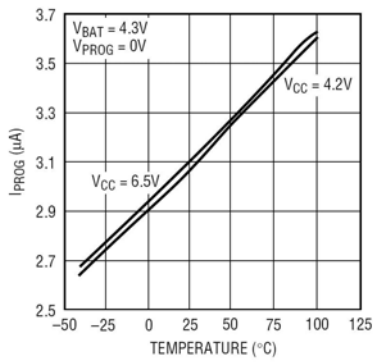
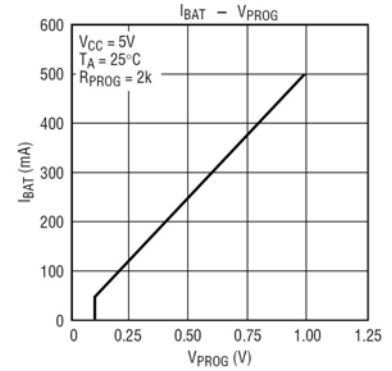
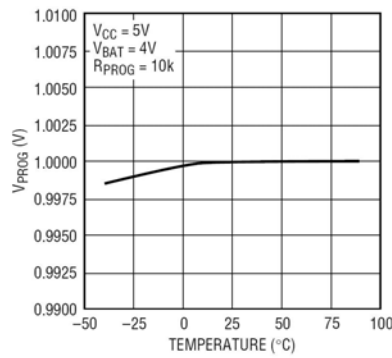
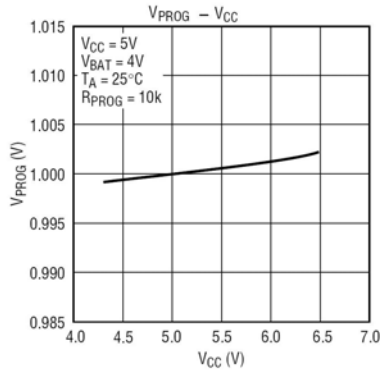

电参数曲线图 / Electrical Characteristic Curve

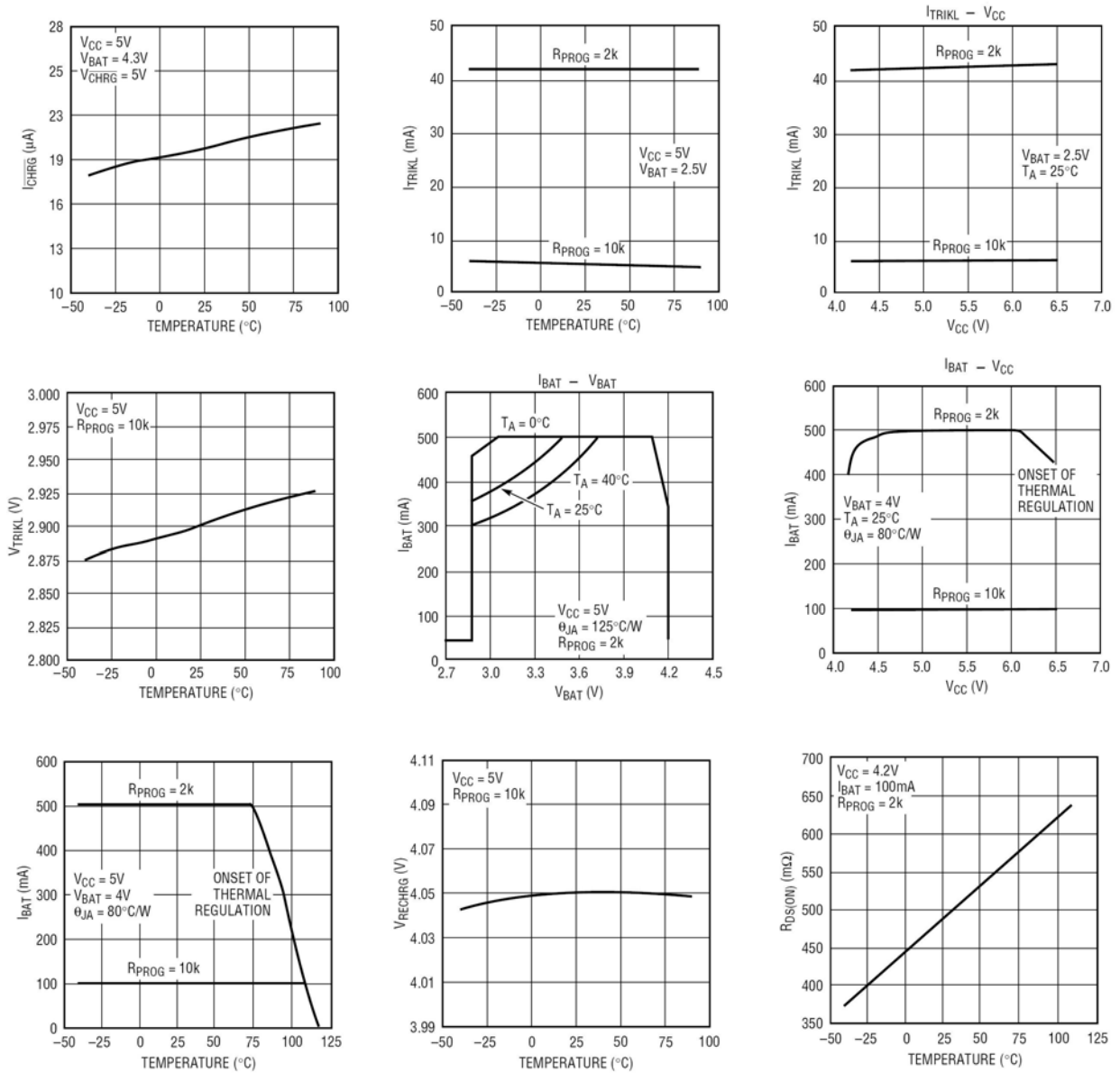

工作原理 / OPERATION

XR4054B是一款采用恒定电流/恒定电压算法的单节锂离子电池充电器。它能够提供800mA的充电电流（借助一个热设计良好的PCB布局）和一个内部P沟道功率MOSFET和热调节电路。无需隔离二极管或外部电流检测电阻器；因此，基本充电器电路仅需要两个外部元件。不仅如此，XR4054B还能够从一个USB电源获得工作电源。

The XR4054B is a single cell lithium-ion battery charger using a constant-current/ constant - voltage algorithm. It can deliver up to 800mA of charge current (using a good thermal PCB layout) with a final float voltage accuracy of $\pm 1\%$. The XR4054B includes an internal P-channel power MOSFET and thermal regulation circuitry. No blocking diode or external current sense resistor is required; thus, the basic charger circuit requires only two external components. Furthermore, the XR4054B is capable of operating from a USB power source.

正常充电循环 / Normal Charge Cycle

当 V_{CC} 引脚电压升至UVLO门限电平以上且在PROG引脚与地之间连接了一个精度为1%的设定电阻器或当一个电池与充电器输出端相连时，一个充电循环开始。如果BAT引脚电平低于2.9V，则充电器进入涓流充电模式。在该模式中，XR4054B提供约1/10的设定充电电流，以便将电流电压提升到一个安全的电平，从而实现满电流充电。

A charge cycle begins when the voltage at the V_{CC} pin rises above the UVLO threshold level and a 1% program resistor is connected from the PROG pin to ground or when a battery is connected to the charger output. If the BAT pin is less than 2.9V, the charger enters trickle charge mode. In this mode, the XR4054B supplies approximately 1/10 the programmed charge current to bring the battery voltage up to a safe level for full current charging.

当BAT引脚电压升至2.9V以上时，充电器进入恒定电流模式，此时向电池提供恒定的充电电流。当BAT引脚电压达到最终浮充电压（4.2V）时，XR4054B进入恒定电压模式，且充电电流开始减小。当充电电流降至设定值的1/10，充电循环结束。

When the BAT pin voltage rises above 2.9V, the charger enters constant-current mode, where the programmed charge current is supplied to the battery. When the BAT pin approaches the final float voltage (4.2V), the XR4054B enters constant-voltage mode and the charge current begins to decrease. When the charge current drops to 1/10 of the programmed value, the charge cycle ends.

充电电流的设定 / Programming Charge Current

充电电流是采用一个连接在PROG引脚与地之间的电阻器来设定的。电流充电电流是PROG引脚输出电流的1000倍。设定电阻器和充电电流采用下列公式来计算：

The charge current is programmed using a single resistor from the PROG pin to ground. The battery charge current is 1000 times the current out of the PROG pin. The program resistor and the charge current are calculated using the following equations:

$$R_{PROG} = \frac{1000V}{I_{CHG}}, \quad I_{CHG} = \frac{1000V}{R_{PROG}}$$

从BAT引脚输出的充电电流可通过监视PROG引脚电压随时确定，公式如下：

The charge current out of the BAT pin can be determined at any time by monitoring the PROG pin voltage using the following equation:

$$I_{BAT} = \frac{V_{PROG}}{R_{PROG}} \cdot 1000$$

充电终止 / Charge Termination

当充电电流在达到最终浮充电压之后降至设定值的1/10时，充电循环被终止。该条件是通过采用一个内部滤波比较器对PROG引脚进行监控来检测的。当PROG引脚电压降至100mV以下的时间超过 t_{TERM} （一般为1.0ms）时，充电被终止。充电电流被锁断，XR4054B进入待机模式，此时输入电源电流降至200 μA 。（注：C/10终止在涓流充电和热限制模式中失效）。

A charge cycle is terminated when the charge current falls to 1/10th the programmed value after the final float voltage is reached. This condition is detected by using an internal, filtered comparator to monitor the PROG pin. When the PROG pin voltage falls below 100mV¹ for longer than t_{TERM} typically 1ms), charging is terminated. The charge current is latched off and the XR4054B enters standby mode, where the input supply current drops to 200 μA . (Note: C/10 termination is disabled in trickle charging and thermal limiting modes).

充电时，BAT引脚上的瞬变负载会使PROG引脚电压在DC充电电流降至设定值的1/10之间短暂地降至100mV以下。终止比较器上的1.0ms滤波时间（ t_{TERM} ）确保这种性质的瞬变负载不会导致充电循环过早终止。一旦平均充电电流降至设定值的1/10以下，XR4054B即终止充电循环并停止通过BAT引脚提供任何电流。在这种状态下，BAT引脚上的所有负载都必须由电池来供电。

When charging, transient loads on the BAT pin can cause the PROG pin to fall below 100mV for short periods of time before the DC charge current has dropped to 1/10th the programmed value. The 1ms filter time (t_{TERM}) on the termination comparator ensures that transient loads of this nature do not result in premature charge cycle termination. Once the average charge current drops below 1/10th the programmed value, the XR4054B terminates the charge cycle and ceases to provide any current through the BAT pin. In this state, all loads on the BAT pin must be supplied by the battery.

在待机模式中，XR4054B对BAT引脚电压进行连续监控。如果该引脚电压降到4.05V的再充电门限(V_{RECHRG})以下，则另一个充电循环开始并再次向电池供应电流。当在待机模式中进行充电循环的手动再启动时，必须取消然后再施加输入电压，或者必须关断充电器并使用PROG引脚进行再启动。图1示出了一个典型充电循环的状态图。

The XR4054B constantly monitors the BAT pin voltage in standby mode. If this voltage drops below the 4.05V recharge threshold (V_{RECHRG}), another charge cycle begins and current is once again supplied to the battery. To manually restart a charge cycle when in standby mode, the input voltage must be removed and reapplied, or the charger must be shut down and restarted using the PROG pin. Figure 1 shows the state diagram of a typical charge cycle.

充电状态指示器 / Charge Status Indicator (CHRG)

充电状态输出具有三种不同的状态：强下拉（约10mA）、弱下拉（约20 μA ）和高阻抗。强下拉状态表示XR4054B处于一个充电循环中。一旦充电循环被终止，则引脚状态由欠压闭锁条件来决定。弱下拉状态表示 V_{CC} 满足UVLO条件且XR4054B处于充电就绪状态。高阻抗状态表示XR4054B处于欠压闭锁模式：要么 V_{CC} 高出BAT引脚电压的幅度不足100mV，要么施加在 V_{CC} 引脚上的电压不足。可采用一个微处理器来区分这三种状态--在“应用信息”部分将对此方法进行讨论。

The charge status output has three different states: strong pull-down (~10mA), weak pull-down (~20 μA) and high impedance. The strong pull-down state indicates that the XR4054B is in a charge cycle. Once the charge cycle has terminated, the pin state is determined by under voltage lockout conditions. A weak pull-down indicates that V_{CC} meets the UVLO conditions and the XR4054B is ready to charge. High impedance indicates that the XR4054B is in under voltage lockout mode: either V_{CC} is less than 100mV above the BAT pin voltage or insufficient voltage is applied to the V_{CC} pin. A microprocessor can be used to distinguish between these three states—this method is discussed in the Applications Information section.

热限制 / Thermal Limiting

如果芯片温度试图上升超过120°C的预设值以上，则一个内部热反馈环路将减小设定的充电电流。该功能可防止XR4054B过热，并允许用户提高给定电路板功率处理能力的上限而没有损坏XR4054B的风险。在保证充电器将在最坏情况条件下自动减小电流的前提下，可根据典型（而不是最坏情况）环境温度来设定充电电流。有关Thin SOT功率方面的考虑将在“应用信息”部分做进一步讨论。

An internal thermal feedback loop reduces the programmed charge current if the die temperature attempts to rise above a preset value of approximately 120°C. This feature protects the XR4054B from excessive temperature and allows the user to push the limits of the power handling capability of a given circuit board without risk of damaging the XR4054B. The charge current can be set according to typical (not worst-case) ambient temperature with the assurance that the charger will automatically reduce the current in worst-case conditions. ThinSOT power considerations are discussed further in the Applications Information section.

欠压闭锁 / Under voltage Lockout (UVLO)

一个内部欠压闭锁电路对输入电压进行监控，并在 V_{CC} 升至欠压闭锁门限以上之前使充电器保持在停机模式。UVLO电路有一个内置的滞后200mV。此外在功率MOSFET的反向电流保护，UVLO电路将使充电器保持在停机模式。如果UVLO比较器发生跳变，则在 V_{CC} 升至比电池电压高100mV之前充电器将不会退出停机模式。

An internal undervoltage lockout circuit monitors the input voltage and keeps the charger in shutdown mode until V_{CC} rises above the undervoltage lockout threshold. The UVLO circuit has a built-in hysteresis of 200mV. Furthermore, to protect against reverse current in the power MOSFET, the UVLO circuit keeps the charger in shutdown mode if V_{CC} falls to within 30mV of the battery voltage. If the UVLO comparator is tripped, the charger will not come out of shutdown mode until V_{CC} rises 100mV above the battery voltage.

手动停机 / Manual Shutdown

在充电循环中的任何时刻都能通过去掉RPROG（从而使RPROG引脚浮置）来把XR4054B置于停机模式。这使得电池漏电流降至 $2\mu\text{A}$ 以下，且电源电流降至 $50\mu\text{A}$ 以下。重新连接设定电阻器可启动一个新的充电循环。

At any point in the charge cycle, the XR4054B can be put into shutdown mode by removing RPROG thus floating the PROG pin. This reduces the battery drain current to less than $2\mu\text{A}$ and the supply current to less than $50\mu\text{A}$. A new charge cycle can be initiated by reconnecting the program resistor.

在手动停机模式中，只要 V_{CC} 高到足以超过UVLO条件，CHRG引脚都将处于弱下拉状态。如果XR4054B处于欠压闭锁模式，则CHRG引脚呈高阻抗状态：要么 V_{CC} 高出BAT引脚电压的幅度不足 100mV ，要么施加在 V_{CC} 引脚上的电压不足。

In manual shutdown, the CHRG pin is in a weak pull-down state as long as V_{CC} is high enough to exceed the UVLO conditions. The CHRG pin is in a high impedance state if the XR4054B is in undervoltage lockout mode: either V_{CC} is within 100mV of the BAT pin voltage or insufficient voltage is applied to the V_{CC} pin.

自动再启动 / Automatic Recharge

一旦充电循环被终止，XR4054B立即采用一个具有 2.0ms 滤波时间（ t_{RECHARGE} ）的比较器来对BAT引脚上的电压进行连续监控。当电池电压降至 4.05V （大致对应于电池容量的80%至90%）以下时，充电循环重新开始。这确保了电池被维持在（或接近）一个满充电状态，并免除了进行周期性充电循环启动的需要。在再充电循环过程中，CHRG引脚输出进入一个强下拉状态。

Once the charge cycle is terminated, the XR4054B continuously monitors the voltage on the BAT pin using a comparator with a 2ms filter time (t_{RECHARGE}). A charge cycle restarts when the battery voltage falls below 4.05V (which corresponds to approximately 80% to 90% battery capacity). This ensures that the battery is kept at or near a fully charged condition and eliminates the need for periodic charge cycle initiations. CHRG output enters a strong pull-down state during recharge cycles.

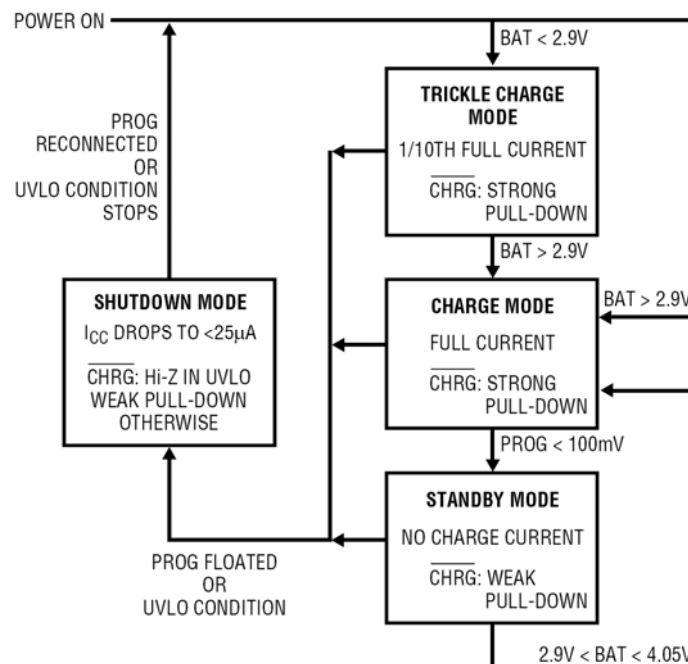

Figure 1. State Diagram of a Typical Charge Cycle

稳定性的考虑 / Stability Considerations

只要电池与充电器的输出端相连，恒定电压模式反馈环路就能够在未采用一个外部电容器的情况下保持稳定。在没有接电池时，为了减小纹波电压，建议采用一个输出电容器。当采用大数值的低ESR陶瓷电容器时，建议增加一个与电容器串联的1Ω电阻器。如果使用的是钽电容，则不需要串联电阻器。

The constant-voltage mode feedback loop is stable without an output capacitor provided a battery is connected to the charger output. With no battery present, an output capacitor is recommended to reduce ripple voltage. When using high value, low ESR ceramic capacitors, it is recommended to add a 1Ω resistor in series with the capacitor. No series resistor is needed if tantalum capacitors are used.

在恒定电流模式中，位于反馈环路中的是PROG引脚，而不是电池。恒定电流模式的稳定性受PROG引脚阻抗的影响。当PROG引脚上没有附加电容会减小设定电阻器的最大容许阻值。PROG引脚上的极点频率应保持在C_{PROG}，则可采用下式来计算R_{PROG}的最大电阻值：

In constant-current mode, the PROG pin is in the feedback loop, not the battery. The constant-current mode stability is affected by the impedance at the PROG pin. With no additional capacitance on the PROG pin, the charger is stable with program resistor values as high as 20k. However, additional capacitance on this node reduces the maximum allowed program resistor. The pole frequency at the PROG pin should be kept above 100kHz. Therefore, if the PROG pin is loaded with a capacitance, C_{PROG}, the following equation can be used to calculate the maximum resistance value for R_{PROG}:

$$R_{\text{PROG}} \leq \frac{1}{2\pi \cdot 10^5 \cdot C_{\text{PROG}}}$$

对用户来说，他们更感兴趣的可能是充电电流，而不是瞬态电流。例如，如果一个运行在低电流模式的开关电源与电池并联，则从BAT引脚流出的平均电流通常比瞬态电流脉冲更加重要。在这种场合，电流通常比瞬态电流脉冲更加重要。在这种场合，可在PROG引脚上采用一个简单的RC滤波器来测量平均的电池电流（如图2所示）。在PROG引脚和滤波电容器之间增设了一个10k电阻器以确保稳定性。

Average, rather than instantaneous, charge current may be of interest to the user. For example, if a switching power supply operating in low current mode is connected in parallel with the battery, the average current being pulled out of the BAT pin is typically of more interest than the instantaneous current pulses. In such a case, a simple RC filter can be used on the PROG pin to measure the average battery current as shown in Figure 2. A 10k resistor has been added between the PROG pin and the filter capacitor to ensure stability.

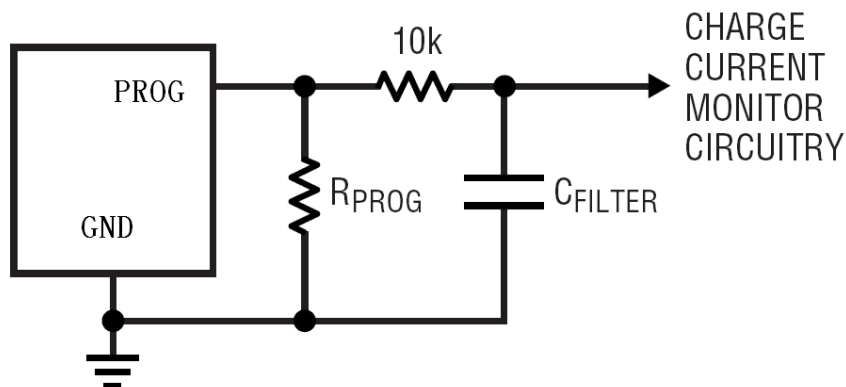

Figure 2. Isolating Capacitive Load on PROG Pin and Filtering

功率损耗 / Power Dissipation

XR4054B因热反馈的缘故而减小充电电流的条件可通过 I_C 中的功率损耗来估算。这种功率损耗几乎全部都是由内部MOSFET产生的——这可由下式近似求出：

The conditions that cause the XR4054B to reduce charge current through thermal feedback can be approximated by considering the power dissipated in the I_C . Nearly all of this power dissipation is generated by the internal MOSFET—this is calculated to be approximately:

$$P_D = (V_{CC} - V_{BAT}) \cdot I_{BAT}$$

式中的 P_D 为耗散的功率， V_{CC} 为输入电源电压， V_{BAT} 为电池电压， I_{BAT} 为充电电流。当热反馈开始对 I_C 提供保护时，环境温度近似为：

Where P_D is the power dissipated, V_{CC} is the input supply voltage, V_{BAT} is the battery voltage and I_{BAT} is the charge current. The approximate ambient temperature at which the thermal feedback begins to protect the I_C is:

$$T_A = 120^\circ\text{C} - P_D \theta_{JA}$$

$$T_A = 120^\circ\text{C} - (V_{CC} - V_{BAT}) \cdot I_{BAT} \cdot \theta_{JA}$$

实例：通过编程使一个从5V USB电源获得工作电源的XR4054B向一个具有3.75V电压的放电锂离子电池提供400mA满幅度电流。假设 θ_{JA} 为 $150^\circ\text{C}/\text{W}$ （请参见电路板布局的考虑），当XR4054B开始减小充电电流时，环境温度近似为：

Example: An XR4054B operating from a 5V USB supply is programmed to supply 400mA full-scale current to a discharged Li-Ion battery with a voltage of 3.75V. Assuming θ_{JA} is $150^\circ\text{C}/\text{W}$ (see Board Layout Considerations), the ambient temperature at which the XR4054B will begin to reduce the charge current is approximately:

$$T_A = 120^\circ\text{C} - (5\text{V} - 3.75\text{V}) \cdot (400\text{mA}) \cdot 150^\circ\text{C}/\text{W}$$

$$T_A = 120^\circ\text{C} - 0.5\text{W} \cdot 150^\circ\text{C}/\text{W} = 120^\circ\text{C} - 75^\circ\text{C}$$

$$T_A = 45^\circ\text{C}$$

XR4054B可在 45°C 以上的环境温度条件下使用，但充电电流将被降至400mA以下。对于一个给定的环境温度，充电电流可有下式近似求出：

The XR4054B can be used above 45°C ambient, but the charge current will be reduced from 400mA. The approximate current at a given ambient temperature can be approximated by:

$$I_{BAT} = \frac{120^\circ\text{C} - T_A}{(V_{CC} - V_{BAT}) \cdot \theta_{JA}}$$

再以 60°C 的环境温度来考虑前面的例子。充电电流将被大约减小至：

Using the previous example with an ambient temperature of 60°C , the charge current will be reduced to approximately:

$$I_{BAT} = \frac{120^\circ\text{C} - 60^\circ\text{C}}{(5\text{V} - 3.75\text{V}) \cdot 150^\circ\text{C}/\text{W}} = \frac{60^\circ\text{C}}{187.5^\circ\text{C}/\text{A}}$$

$$I_{BAT} = 320\text{mA}$$

功率损耗 / Power Dissipation

不仅如此，正如工作原理部分所讨论的那样，当热反馈使充电电流减小时，PROG引脚上的电压也将成比例地减小。

Moreover, when thermal feedback reduces the charge current, the voltage at the PROG pin is also reduced proportionally as discussed in the Operation section.

切记不需要在XR4054B应用设计中考虑最坏的热条件，这一点很重要，因为该 I_c 将在结温达到120°C左右时自动降低功耗。

It is important to remember that XR4054B applications do not need to be designed for worst-case thermal conditions since the IC will automatically reduce power dissipation when the junction temperature reaches approximately 120°C.

热考虑 / Thermal Considerations

由于SOT封装的外形尺寸很小，因此，需要采用一个热设计精良的PC板布局以最大程度地增加可使用的充电电流，这一点非常重要。用于耗散 I_c 所产生的热量的散热通路从芯片至引线框架，并通过峰值后引线（特别是接地引线）到达PC板铜面。PC板铜面为散热器。引脚相连的铜箔面积应尽可能地宽阔，并向外延伸至较大的铜面积，以便将热量散播到周围环境中。至内部或背部铜电路层的通孔在改善充电器的总体热性能方面也是颇有用途的。当进行PC板布局设计时，电路板上与充电器无关的其他热源也是必须予以考虑的，因为它们将对总体温升和最大充电电流有所影响。

Because of the small size of the Thin SOT package, it is very important to use a good thermal PC board layout to maximize the available charge current. The thermal path for the heat generated by the IC is from the die to the copper lead frame, through the package leads, (especially the ground lead) to the PC board copper. The PC board copper is the heat sink. The footprint copper pads should be as wide as possible and expand out to larger copper areas to spread and dissipate the heat to the surrounding ambient. Feed through vias to inner or backside copper layers are also useful in improving the overall thermal performance of the charger. Other heat sources on the board, not related to the charger, must also be considered when designing a PC board layout because they will affect overall temperature rise and the maximum charge current.

下表罗列了几种不同电路板尺寸和铜面积条件下的热阻。所有的测量结果都是在静止空气中的3/32" FR-4 电路板上（器件安装于其顶面）获得的。

The following table lists thermal resistance for several different board sizes and copper areas. All measurements were taken in still air on 3/32" FR-4 board with the device mounted on top side.

Table 1. 实测热阻（双层电路板*） Measured Thermal Resistance (2-Layer Board*)

Copper Area		Board Area	Thermal Resistance Junction-to-Ambient
Topside	Backside		
2500mm ²	2500mm ²	2500mm ²	125°C/W
1000mm ²	2500mm ²	2500mm ²	125°C/W
225mm ²	2500mm ²	2500mm ²	130°C/W
100mm ²	2500mm ²	2500mm ²	135°C/W
50mm ²	2500mm ²	2500mm ²	150°C/W

*每层采用1盎司铜箔 / Each layer uses one ounce copper

Table 2. 实测热阻（四层电路板*） Measured Thermal Resistance (4-Layer Board)**

Copper Area (Each Side)	Board Area	Thermal Resistance Junction-to-Ambient
2500mm ^{2***}	2500mm ²	80°C/W

*顶层和底层采用2盎司铜箔，内层采用1盎司铜箔 / Top and bottom layers use two ounce copper, inner layers use one ounce copper.

**总铜面积为10000mm² / 10,000mm² total copper area

增加热调节电流 / Increasing Thermal Regulation Current

降低内部MOSFET 两端的压降能够显著减少 I_C 中的功耗。在热调节期间，这具有增加输送至电池的电流的作用。对策之一是通过一个外部元件（例如一个电阻器或二极管）将一部分功率耗散掉。

Reducing the voltage drop across the internal MOSFET can significantly decrease the power dissipation in the IC. This has the effect of increasing the current delivered to the battery during thermal regulation. One method is by dissipating some of the power through an external component such as a resistor or diode.

实例：通过编程使一个从5V交流适配器获得工作电源的XR4054B向一个具有3.75V电压的放电锂离子电池提供800mA的满幅充电电流。假设 θ_{JA} 为 $125^\circ\text{C}/\text{W}$ ，则在 25°C 的环境温度条件下，充电电流近似为：

Example: An XR4054B operating from a 5V wall adapter is programmed to supply 800mA full-scale current to a discharged Li-Ion battery with a voltage of 3.75V. Assuming θ_{JA} is $125^\circ\text{C}/\text{W}$, the approximate charge current at an ambient temperature of 25°C is:

$$I_{\text{BAT}} = \frac{120^\circ\text{C} - 25^\circ\text{C}}{(5\text{V} - 3.75\text{V}) \cdot 125^\circ\text{C}/\text{W}} = 608\text{mA}$$

通过降低一个与5V 交流适配器串联的电阻器两端的电压（如图3 所示），可减少片上功耗，从而增大热调整的充电电流：

By dropping voltage across a resistor in series with a 5V wall adapter (shown in Figure 3), the on-chip power dissipation can be decreased, thus increasing the thermally regulated charge current

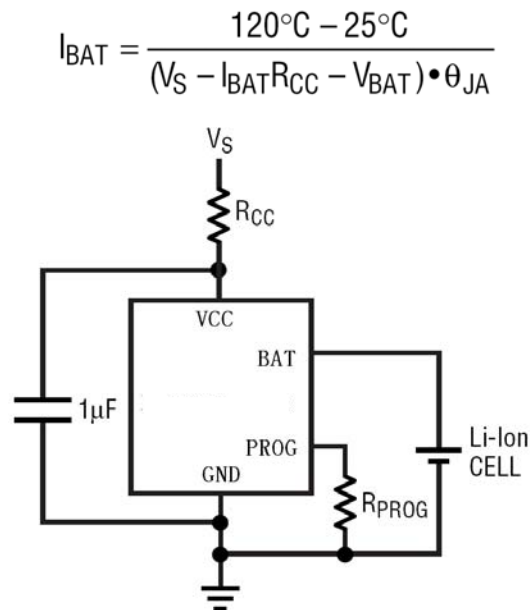

Figure 3. A Circuit to Maximize Thermal Mode Charge Current

利用二次方程可求出 I_{BAT} 。

Solving for I_{BAT} using the quadratic formula².

$$I_{\text{BAT}} = \frac{(V_S - V_{\text{BAT}}) - \sqrt{(V_S - V_{\text{BAT}})^2 - \frac{4R_{\text{CC}}(120^\circ\text{C} - T_A)}{\theta_{\text{JA}}}}}{2R_{\text{CC}}}$$

增加热调节电流 / Increasing Thermal Regulation Current

取 $R_{CC}=0.25\Omega$ 、 $V_S=5V$ 、 $V_{BAT}=3.75V$ 、 $T_A=25^\circ C$ 且 $\theta_{JA}=125^\circ C/W$ ，我们可以计算出热调整的充电电流： $I_{BAT}=708.4mA$

Using $R_{CC} = 0.25\Omega$, $V_S = 5V$, $V_{BAT} = 3.75V$, $T_A = 25^\circ C$ and $\theta_{JA} = 125^\circ C/W$ we can calculate the thermally regulated charge current to be: $I_{BAT} = 708.4mA$

虽然这种应用可以在热调整模式中向电池输送更多的能量并缩短充电时间，但在电压模式中，如果 V_{CC} 变得足够低而使XR4054B处于低压降状态，则它实际上有可能延长充电时间。图4示出了该电路是如何随着 R_{CC} 的变大而导致电压下降的。

While this application delivers more energy to the battery and reduces charge time in thermal mode, it may actually lengthen charge time in voltage mode if V_{CC} becomes low enough to put the XR4054B into dropout. Figure 4 shows how this circuit can result in dropout as R_{CC} becomes large.

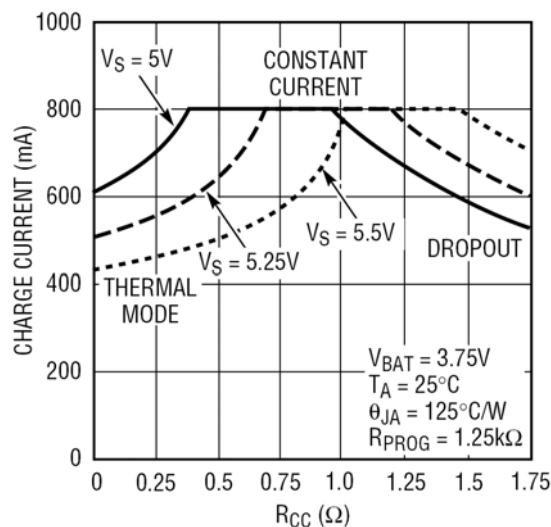

Figure 4. Charge Current vs R_{CC}

当为了保持较小的元件尺寸并避免发生压降而使 R_{CC} 值最小化时，该技术能起到最佳的作用。请牢记 选择一个具有足够功率处理能力的电阻器。

This technique works best when R_{CC} values are minimized to keep component size small and avoid dropout. Remember to choose a resistor with adequate power handling capability.

V_{CC} 旁路电容器 / V_{CC} Bypass Capacitor

输入旁路可以使用多种类型的电容器。然而，在采用多层陶瓷电容器时必须谨慎。由于有些类型的陶瓷电容器具有自谐振和高Q值的特点，因此，在某些启动条件下（比如将充电器输入与一个工作中的电源相连）有可能产生高的电压瞬态信号。增加一个与X5R陶瓷电容器串联的 1.5Ω 电阻器将最大限度地减小启动电压瞬态信号。

Many types of capacitors can be used for input bypassing, however, caution must be exercised when using multilayer ceramic capacitors. Because of the self-resonant and high Q characteristics of some types of ceramic capacitors, high voltage transients can be generated under some start-up conditions, such as connecting the charger input to a live power source. Adding a 1.5Ω resistor in series with an X5R ceramic capacitor will minimize start-up voltage transients. For more information, refer to Application Note 88.

充电电流软启动 / Charge Current Soft-Start

XR4054B包括一个用于在充电循环开始时最大限度地减小涌入电流的软启动电路。当一个充电循环被启动时，充电电流将在100 μ s左右的时间里从0上升至满幅全标度值。在启动过程中，这能够起到最大限度地减小电源上的瞬变电流负载的作用。

The XR4054B includes a soft-start circuit to minimize the inrush current at the start of a charge cycle. When a charge cycle is initiated, the charge current ramps from zero to the full-scale current over a period of approximately 100 μ s. This has the effect of minimizing the transient current load on the power supply during start-up.

CHRG引脚能够提供输入电压高于欠压闭锁门限电平的指示。一个约20 μ A的弱下拉电流表示V_{CC}引脚上施加了开始充电循环所需的足够电压。当一个放电电池被连接到充电器时，充电循环的恒定电流部分开始，CHRG引脚电平被拉至地。CHRG引脚能够吸收高达10mA的电流，以驱动一个用于指示充电循环正在进行之中的LED。

The CHRG pin can provide an indication that the input voltage is greater than the under voltage lockout threshold level. A weak pull-down current of approximately 20 μ A indicates that sufficient voltage is applied to V_{CC} to begin charging. When a discharged battery is connected to the charger, the constant current portion of the charge cycle begins and the CHRG pin pulls to ground. The CHRG pin can sink up to 10mA to drive an LED that indicates that a charge cycle is in progress.

当电池接近充满时，充电器进入充电循环的恒定电压部分，充电电流开始下降。当充电电流降至不足设定电流的1/10时，充电循环结束且强下拉被一个20 μ A下拉所取代，表示充电循环已经结束。如果输入电压被拿掉或降至欠压闭锁门限以下，则CHRG引脚变成高阻抗。利用两个不同阻值的上拉电阻器，一个微处理器能够从该引脚检测出所有三种状态，如图5所示。

When the battery is nearing full charge, the charger enters the constant-voltage portion of the charge cycle and the charge current begins to drop. When the charge current drops below 1/10 of the programmed current, the charge cycle ends and the strong pull-down is replaced by the 20 μ A pull-down, indicating that the charge cycle has ended. If the input voltage is removed or drops below the under voltage lockout threshold, the CHRG pin becomes high impedance. Figure 5 shows that by using two different value pull-up resistors, a microprocessor can detect all three states from this pin.

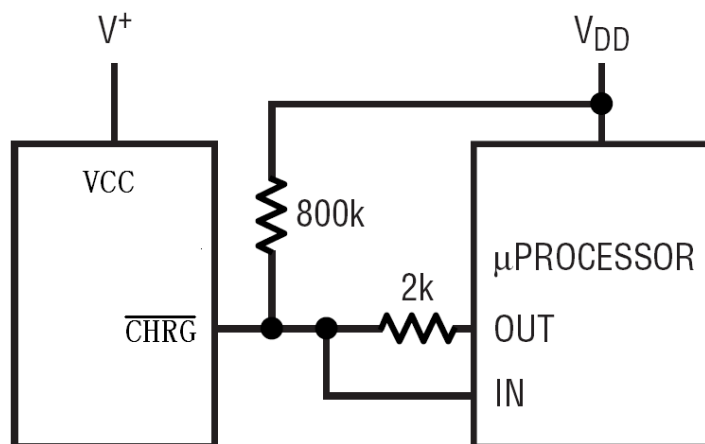

Figure 5. Using a Microprocessor to Determine CHRG State

CHRG状态输出引脚 / CHRG Status Output Pin

为了在XR4054B处于充电模式时进行检测,将数字输出引脚(OUT)强制为高电平并测量CHRG引脚上的电压。即使在采用2k上拉电阻器的情况下,N沟道MOSFET也将把该引脚拉至低电平。一旦充电循环终止,N沟道MOSFET即被关断,并且一个20 μ A的电流源被连接至CHRG引脚。IN引脚随后将由2K上拉电阻器拉至高电平。为了确定是否存在一个弱下拉电流,应将OUT引脚强制为高阻抗状态。弱电流源将通过一个800K电阻器将IN引脚拉至低电平;如果CHRG引脚为高阻抗,则IN引脚将被拉至高电平,表示器件处于一个UVLO状态。

To detect when the XR4054B is in charge mode, force the digital output pin (OUT) high and measure the voltage at the $\overline{\text{CHRG}}$ pin. The N-channel MOSFET will pull the pin voltage low even with the 2k pull-up resistor. Once the charge cycle terminates, the N-channel MOSFET is turned off and a 20 μ A current source is connected to the $\overline{\text{CHRG}}$ pin. The IN pin will then be pulled high by the 2k pull-up resistor. To determine if there is a weak pull-down current, the OUT pin should be forced to a high impedance state. The weak current source will pull the IN pin low through the 800k resistor; if $\overline{\text{CHRG}}$ is high impedance, the IN pin will be pulled high, indicating that the part is in a UVLO state.

CHRG状态输出引脚 / CHRG Status Output Pin

在有些应用中,需要在 V_{CC} 上进行反向极性电压保护。如果电源电压足够高,则可采用一个串联隔离二极管。在其他必须保持低降压的场合,可以采用一个P沟道MOSFET(如图6所示)。

In some applications, protection from reverse polarity voltage on V_{CC} is desired. If the supply voltage is high enough, a series blocking diode can be used. In other cases, where the voltage drop must be kept low a P-channel MOSFET can be used (as shown in Figure 6).

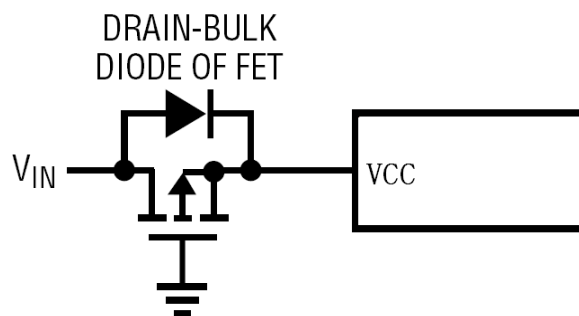

Figure 6. Low Loss Input Reverse Polarity Protection

USB 和交流适配器电源 / USB and Wall Adapter Power

XR4054B允许从一个交流适配器或一个USB 端口进行充电。图7示出了如何将交流适配器与USB电源输入加以组合的一个实例。一个P沟道MOSFET (MP1) 被用于防止交流适配器接入时信号反向传入USB端口, 而一个肖特基二极管 (D1) 则被用于防止USB功率在经过1K下拉电阻器时产生损耗。

The XR4054B allows charging from both a wall adapter and a USB port. Figure 7 shows an example of how to combine wall adapter and USB power inputs. A P-channel MOSFET, MP1, is used to prevent back conducting into the USB port when a wall adapter is present and a Schottky diode, D1, is used to prevent USB power loss through the 1k pull-down resistor.

一般来说, 交流适配器能够提供比电流限值为500mA的USB端口大得多的电流。因此, 当交流适配器接入时, 可采用一个N沟道MOSFET (MN1) 和一个附加的10K设定电阻器来把充电电流增加至600mA。

Typically a wall adapter can supply more current than the 500mA-limited USB port. Therefore, an N-channel MOSFET, MN1, and an extra 10k program resistor are used to increase the charge current to 600mA when the wall adapter is present.

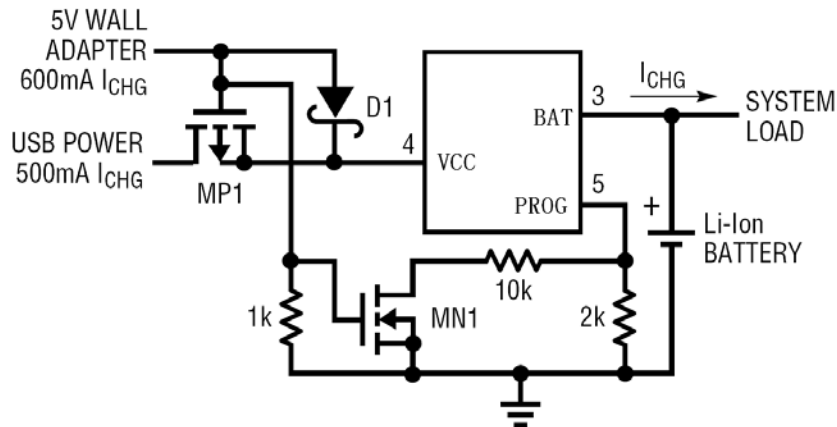
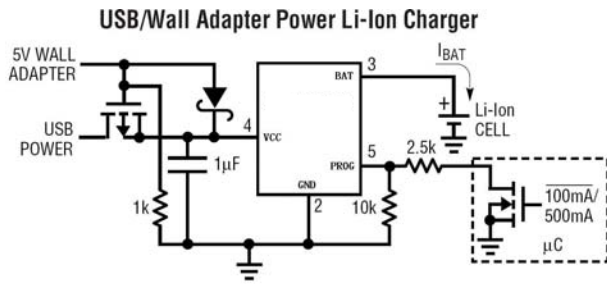
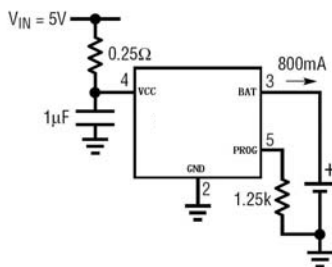

Figure 7. Combining Wall Adapter and USB Power

典型应用 / Typical Applications



800mA Li-Ion Charger with External Power Dissipation



Full Featured Single Cell Li-Ion Charger

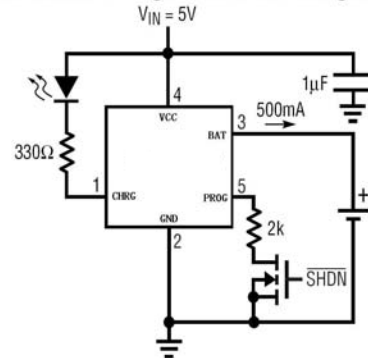

Basic Li-Ion Charger with Reverse Polarity Input Protection

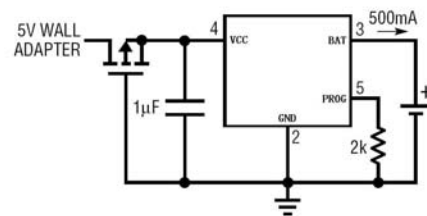

外形尺寸图 / Package Dimensions

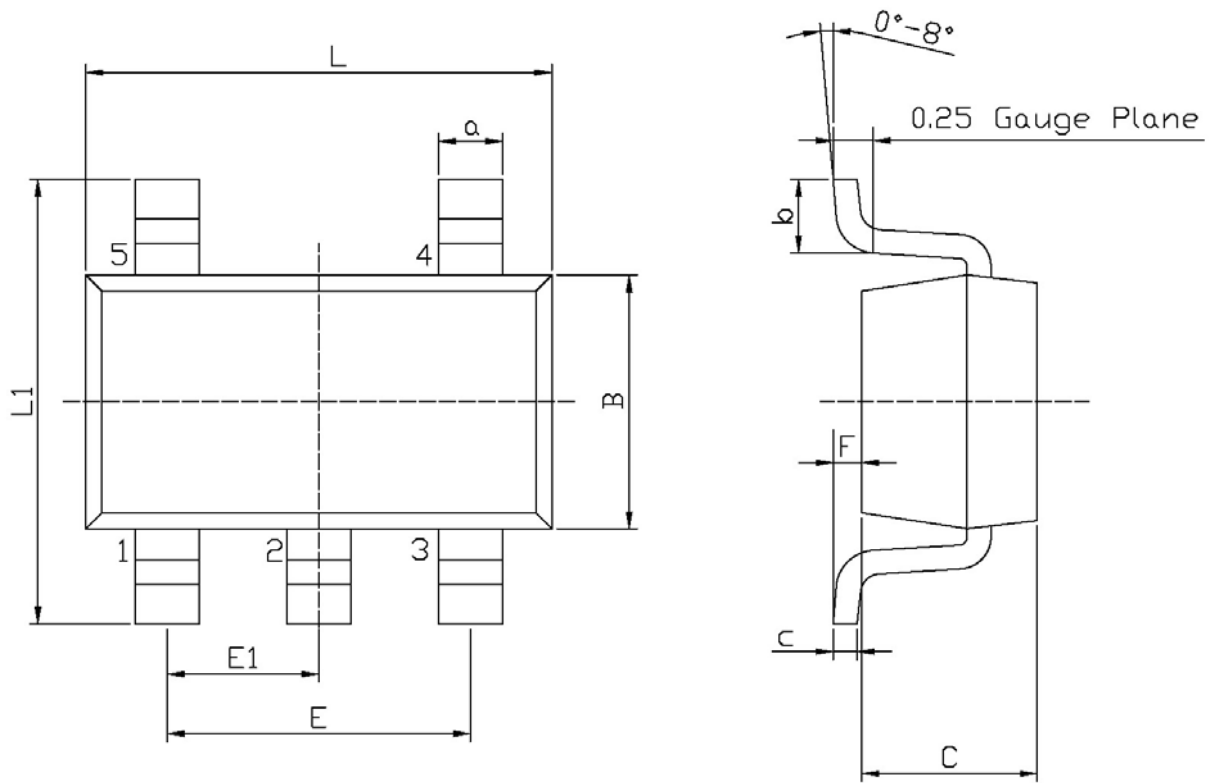

Unit: mm

Symbol	Dimensions In Millimeters		Symbol	Dimensions In Millimeters	
	Min	Max		Min	Max
L	2.82	3.02	E1	0.85	1.05
B	1.50	1.70	a	0.35	0.50
C	0.90	1.30	c	0.10	0.20
L1	2.60	3.00	b	0.35	0.55
E	1.80	2.00	F	0	0.15

SOT23-5

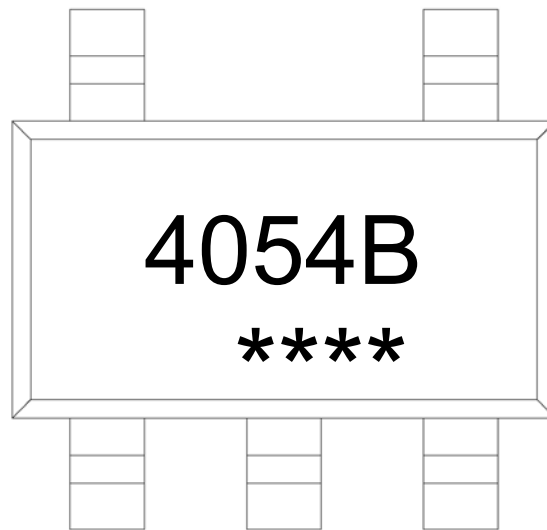

说明：

4054B： 为型号代码

****： 为生产批号代码，随生产批号变化。

Note:

4054B: Product Type.

****: Lot No. Code, code change with Lot No.

回流焊温度曲线图(无铅) / Temperature Profile for IR Reflow Soldering(Pb-Free)

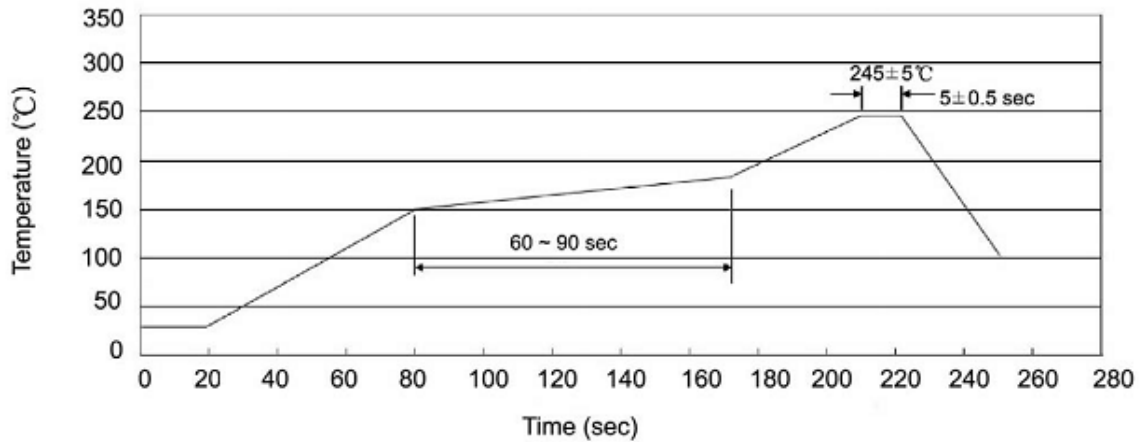

说明：

- 1、预热温度 150 ~ 180℃，时间 60 ~ 90sec;
- 2、峰值温度 245±5℃，时间持续为 5±0.5sec;
- 3、焊接制程冷却速度为 2 ~ 10℃/sec.

Note:

- 1.Preheating:150~180℃, Time:60~90sec.
- 2.Peak Temp.:245±5℃, Duration:5±0.5sec.
3. Cooling Speed: 2~10℃/sec.

耐焊接热试验条件 / Resistance to Soldering Heat Test Conditions

温度：260±5℃

时间：10±1 sec.

Temp.:260±5℃

Time:10±1 sec

包装规格 / Packaging SPEC.

卷盘包装 / REEL

Package Type 封装形式	Units 包装数量					Dimension 包装尺寸 (unit: mm ³)		
	Units/Reel 只/卷盘	Reels/Inner Box 卷盘/盒	Units/Inner Box 只/盒	Inner Boxes/Outer Box 盒/箱	Units/Outer Box 只/箱	Reel	Inner Box 盒	Outer Box 箱
SOT23-5/6	3,000	10	30,000	4	120,000	7" ?8	210×205×205	435×225×420

使用说明 / Notices